

AST 70

SINGLE CARTRIDGE SEAL



Field Rebuildable

No more waiting for seal repairs, and no more worries about installing exchange seals that might have previously held hazardous materials, because the AST 70 is easy to rebuild on site using standard tools.

No Measurement Required

Simply slide the seal onto the shaft, bolt down the gland, tighten the set screws, and remove the centering blocks.

Easy replacement on split case and vertical pumps

No pump teardown required. Just slide the seal over the end of the shaft.

No Shaft Fretting

The static O-ring eliminates any grooving or fretting of the shaft.

Easy Impeller Adjustment

Adjust impeller clearance without removing the seal or dismantling the pump.

Use AST Mechanical Seals for the ultimate in sealing simplicity. The AST 70 is designed for a wide range of applications including

- Food Processing
- Mining Services
- Pulp and Paper
- Corn Processing
- Marine Operations
- Phosphate Production
- Chemical Processing
- Sugar Refining
- Brewing and Distilling
- Pharmaceuticals
- Petroleum Systems
- Waste Treatment
- Water Treatment
- Power and Energy

ADVANCED SEALING
TECHNOLOGY

Reliable Sealing for Rotating Equipment



AST 70

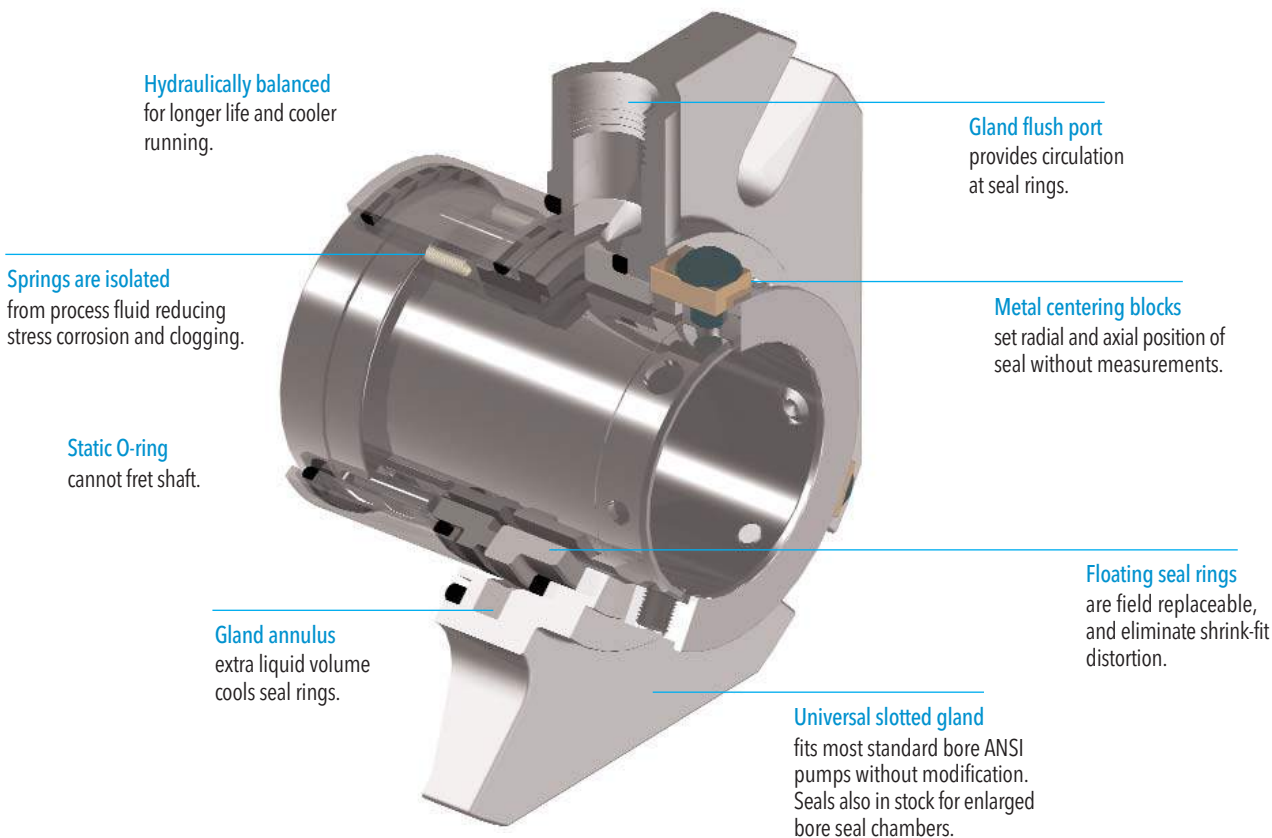

OFF THE SHELF...

AST 70 seals are available off-the-shelf to fit most ANSI pumps, including enlarged bore pumps, without modification. Seals are in stock to fit many split case, positive displacement, and vertical turbine pumps.

...or ENGINEERED

We design and build special AST 70 seals for vertical turbine pumps, large split case pumps, and other systems that require more than a standard seal. Rebuild parts are still off-the-shelf.

MATERIALS OF CONSTRUCTION

Metal components:	316 Stainless Steel standard; Alloy 20, Titanium, and Hastelloy C-276 ¹ available
Rotating seal ring:	Carbon-Graphite or Graphite-Loaded Sintered Silicon Carbide
Stationary seal ring:	Sintered Silicon Carbide or Tungsten Carbide
Springs:	Hastelloy C-276
O-rings:	Fluoroelastomer, EPDM, Aflas ² , or Isolast ³ perfluoroelastomer

OPERATING LIMITS

Pressure:	28 in (710 mm) Hg vacuum to 400 PSIG (28 bar) maximum, depending on shaft size and speed.
Temperature:	To 500°F (260°C), depending on O-ring elastomer limits in fluid sealed

Notes: ¹Trademark of Haynes International Inc., ²Trademark of Asahi Glass Co. Ltd., ³Trademark of Busak+Shamban