

.75HP U6K CHEM-RESIST SUBMERSIBLE PUMPS for MINE DEWATERING

The Ideal Pump for All
Drainage Work.

Lightweight, Compact
and Easily Portable

- High impact, corrosion resistant plastic pump body, top cover, impeller.
- Stainless steel encapsulated motor, rotor shaft & fasteners.
- Silicon carbide mechanical seal allows “dry” running.
- Class B insulation. Easy-lift handle.
- Strainer base, open impeller (10mm solids handling), 1 ¼” MPT discharge.
- Safety yellow body.
- Continuous operation to 140°F if fully immersed.



The “Minion”!

SPECIFICATIONS

The U6K CHEM-RESIST pumps are available with built-in level switch as illustrated in the photo above for fixed differential automatic level control if needed.

TYPE	VOLTAGE	MOTOR	RPM	kW input	F.L.C.	Thermal Protection	WEIGHT
U6K-E(S)	115V or 220V	.75 HP	3600	800	7/4 Amp	Built-In	14.5 lbs.
U6K-D(S)	230V or 460V	.75 HP	3600	800	2.2/1.2 Amp	Built-In	14.5 lbs.



STANCOR™
Pump & Control Solutions

BUILDING TRADES | CONSTRUCTION | MINING | UTILITIES | WASTEWATER

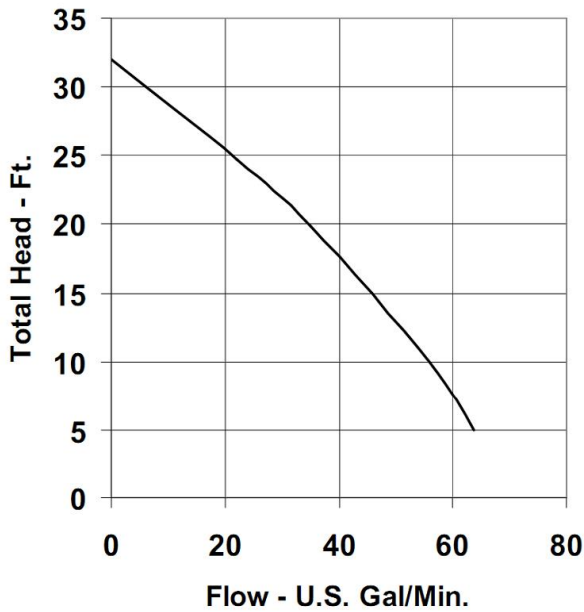

Chem-Resist
 Type/U6K-E (manual) ES (automatic) -.75HP
 Voltage 115 or 220 Volt
 Model – Chem U6K-D (manual) DS (automatic)
 Voltage 230 or 460 Volt

Accessories

Combined starting/level control float arm
 Separate auto control CB-1000 for single phase pumps
 Separate auto control CB-2000 for 3-phase pumps

Capacity ± 8%
 Head ± 6%
 HP absorbed ± 8%

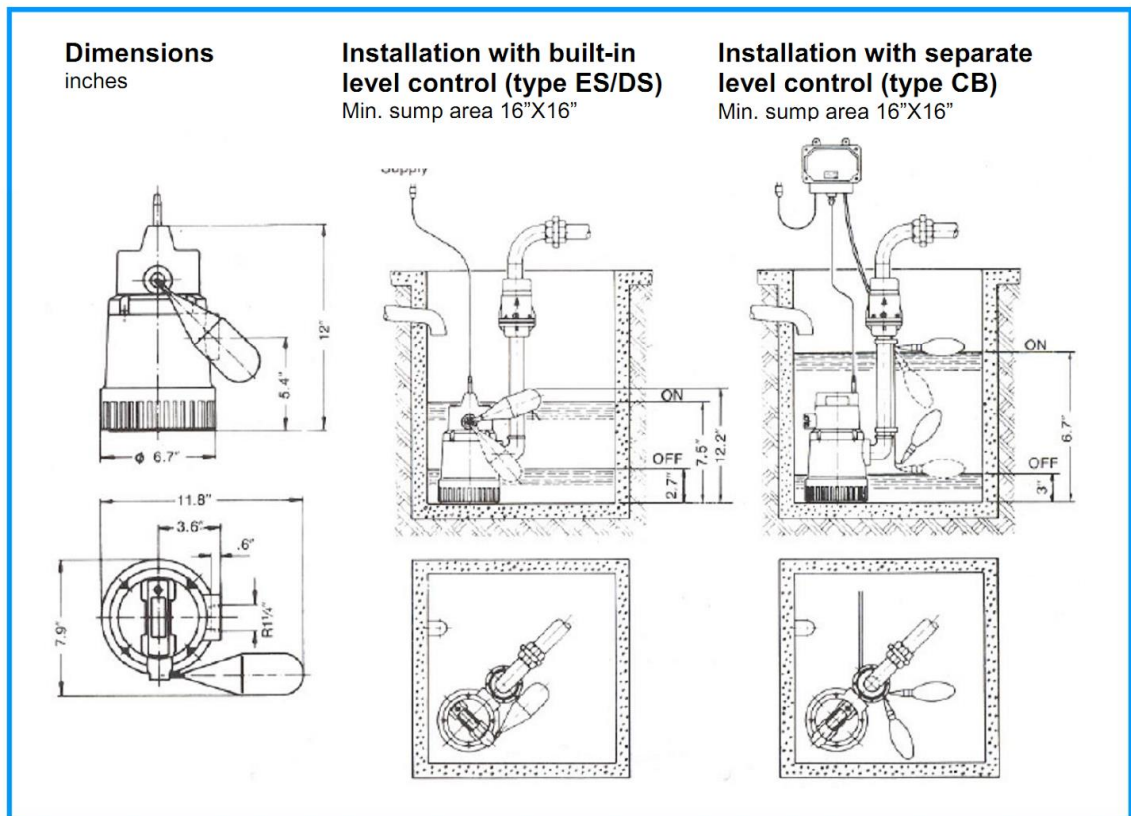

FOR MORE INFORMATION CONTACT:

Applied Process Equipment
 480-998-4097 * sales@apewater.com

