

3D SERIES PUMP

THREE-SCREW PUMPS STANDARD PRODUCT SPECIFICATIONS



The IMO® 3D Series are general purpose three screw pumps available in 19 different displacements. They incorporate full hydraulic balance which cancels axial and radial thrust due to discharge pressure.

Mechanical sealed pumps have a single external ball bearing that does not rely on the lubricating qualities of the pumped liquid. The pumps are equipped with replaceable housings (liners) and most sizes are available with an optional steel case. Axial inlets also available in most sizes.



Low Pressure Lube Oil Pumps for Mining Applications

PRODUCT SPECIFICATIONS

Casing	High tensile, close-grained cast iron. Cast steel available in sizes 156 and larger.
Rotor housing	Pearlitic gray iron.
Power rotor	Alloy steel, hardened and ground.
Idler rotor	Pearlitic gray iron, hardened and ground.
Gaskets	Cellulose plant fiber.
Shaft seal	Mechanical seal.
Outlet pressure	500 PSIG (34.5 BAR) maximum
Inlet pressure	75 PSIG (5.2 BAR) maximum, sizes 106-187 50 PSIG (3.4 BAR) maximum, sizes 218 and up <i>Designs available for inlet pressures to 300 psig with dimensions slightly different than standard.</i>
Viscosity	33-15,000 SSU
Speed	See performance chart
Mounting	Foot or flange mounted, horizontal or vertical



PERFORMANCE CHART

Shown at 250 PSID (17 BAR), 200 SSU (43 CST)

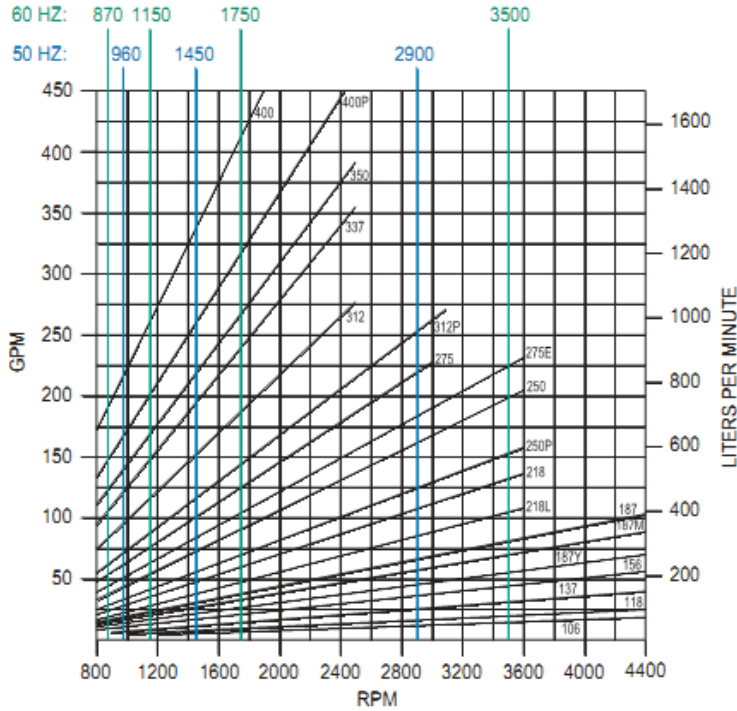

Cast iron, sizes 106 thru 187 have NPT inlet and outlet ports.

Sizes 218 up, flanged inlets are 125# ANSI FF for iron cased pumps and 150# ANSI FF for cast steel.

Cast steel size 156 has socket weld inlet and outlet ports.

Cast steel size 187 has socket weld outlet and 150# ANSI FF flange inlet.

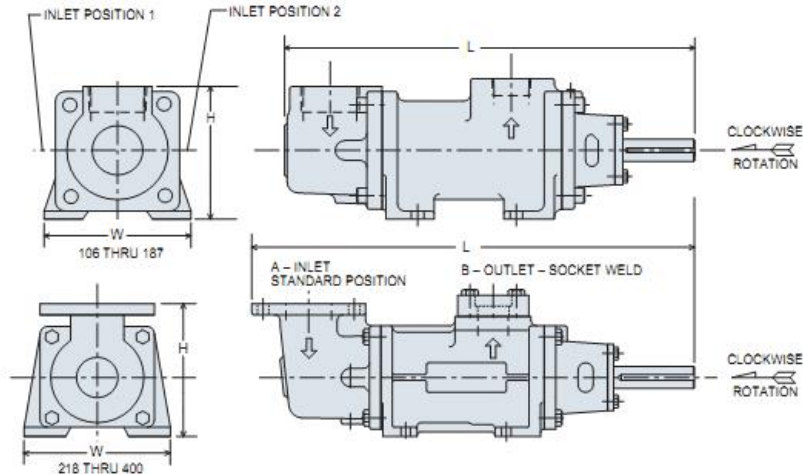

Size	A		B		H		L		W		WEIGHT	
	INCH	MM	INCH	MM	INCH	MM	INCH	MM	INCH	MM	LBS	KG
106	1	25.4	1	25.4	5 5/8	143	14 7/16	367	6	153	41	18.6
118	1 1/2	38.1	1	25.4	5 7/8	150	15 1/4	388	6 1/4	159	44	20
137	1 1/2	38.1	1	25.4	6 1/8	156	16 11/16	424	6 1/2	166	50	22.7
156	2	50.8	1 1/2	38.1	6 1/2	166	18 5/8	474	7	178	66	30
187, Y, M	2 1/2	63.5	1 1/2	38.1	6 3/4	172	20 5/16	516	7 1/2	191	82	37.3
218, L	3	76.2	2	50.8	9	229	29 3/16	742	9	229	154	70
250, P	4	101.6	2 1/2	63.5	10 3/4	273	32 1/4	820	10	254	202	91.8
275, E	4	101.6	3	76.2	11 1/8	283	32 11/16	831	11	280	246	112
312, P	4	101.6	3	76.2	11 3/4	299	35 1/4	896	12	305	281	128
337, 350	5	127	4	101.6	13 1/4	337	38 9/16	980	13	331	410	186
400, P	6	152.4	4	101.6	16	407	41 5/8	1058	14	356	601	273

FOR MORE INFORMATION CONTACT:
APPLIED PROCESS EQUIPOMENT, INC.
 9332 N 95th Way
 Scottsdale, AZ 85258
 480-998-4097, sales@apewater.com

Stocking distributor for IMO pumps & repair kits