



911 series

ANSI Centrifugal
Process Pumps



Barmesa[®] Pumps

Quality Pumps Since 1953

What is an ANSI pumps?

In 1977, the American National Standard Institute (ANSI) established criteria for centrifugal pumps in terms of dimension, chemical composition of the materials and safety specifications, to cover the needs from chemical process industry.

Design features were established, such as being self-venting, foot mounted, center line discharge and back pull-out disassembly

The ANSI pump revolves around a basic hydraulic and mechanical design concept to ensure greater efficiency in the range of operation, flexible application and superior interchangeability.

- ▶ More than 30 different models.
- ▶ Speed and ease of repair.
- ▶ Low initial and operating costs.
- ▶ Interchangeable with other brands.
- ▶ Capacities up to 4000 GPM.
- ▶ Pressure Head up to 670 ft.
- ▶ Temperatures up to 350 °F (177 °C).
- ▶ Pressures up to 285 PSIG.

- ▶ Serving industries:
 - ▶ Automotive
 - ▶ Food & beverage
 - ▶ Textile
 - ▶ Petrochemical
 - ▶ Pharmaceutical
 - ▶ Chemical
 - ▶ Pulps & paper
 - ▶ General industry

- ▶ Available materials:
 - ▶ Ductile iron
 - ▶ 316 SS
 - ▶ CD4MCu

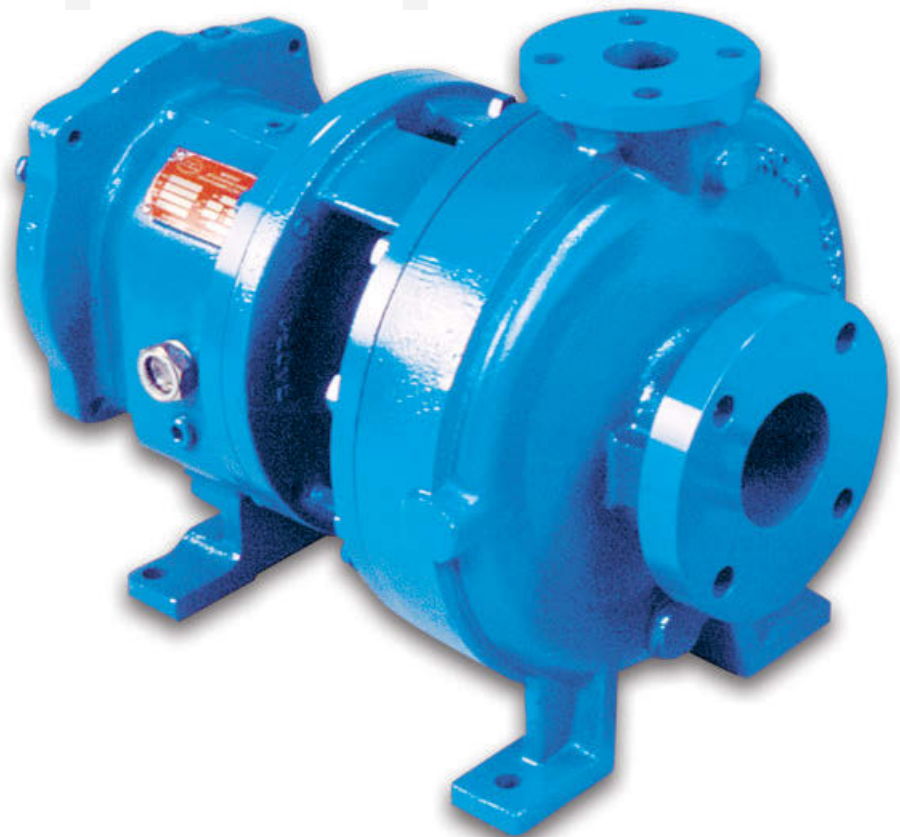



Automotive



Food & beverage

► Reliability

With experience over 60 years manufacturing pumps, our engineering enable us to understand the requirements of the industry and suggest the appropriate solution.

High reliability is due to the design of the pump itself. The 911 Series meets and exceeds ANSI B 73.1

► Durability

The Barmesa Pumps 911 Series are designed to the highest expectations of durability and easy maintenance, increasing equipment life.

The open type impeller and seal chamber were designed to facilitate the handling of corrosive and abrasive liquids.

The bearing design minimizes deflection on the shaft.

► Versatility

A variety of interchangeable liquid ends ensures maximum flexibility.

The modular design ensures easy conversion to new requirements and changes in the plant installation.

► Low initial and operations costs

In the Barmesa process pumps 911 Series, you get low initial and operating costs, unlike other brands that also offer a low cost when you purchase your equipment, but an excessive cost on their spare parts.

► Fast and ease of repair

All parts of the Barmesa process pumps 911 Series are fully interchangeable with thousands of pumps on the market, because of this and our extensive stock, a repair can be perform very quickly.

Barmesa pumps are your best choice.



Textile



Petrochemical industry



▶ Fully open impeller

- ▶ High efficiency, eliminates recirculation.
- ▶ Superior handling of solids, abrasive and corrosive liquids.
- ▶ Vanes in the back side reduce hydraulic and back pressure in the seal chamber.
- ▶ Teflon impeller gasket.
- ▶ Available materials: ductile Iron, 316 SS and CD4MCu.

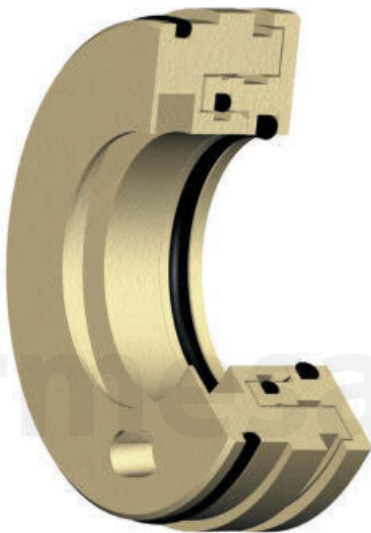

▶ Inpro VBX labyrinth seal

Isolates bearings from the environment, ensuring that it will remain properly lubricated and unpolluted throughout its life.

- ▶ Minimum number of components: motor, stator and rings.
- ▶ Isolate the bearings from contamination.
- ▶ Multiport for proper drainage.

▶ Seal solutions

The seal plate is designed to accept a variety of cooling plans to meet specific user requirements.

1 Single interior seal

- ▶ Non-corrosive liquids to moderately corrosive.
- ▶ Mild abrasives.
- ▶ Pumping liquids with good lubricating qualities.

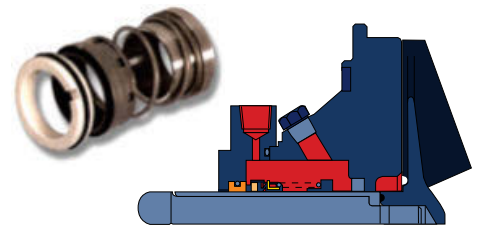

2 Conventional double seal

- ▶ Liquids not compatible with single seals.
- ▶ Toxic, hazardous, abrasive and corrosive liquids.
- ▶ When the pump is operating under low flow conditions.

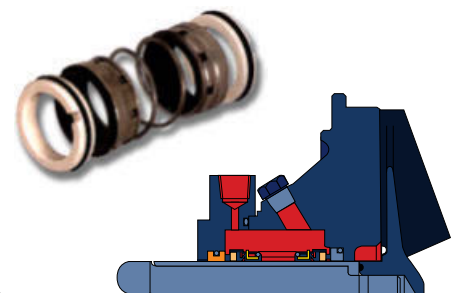

Single cartridge seal

- ▶ Non-corrosive liquids to moderately corrosive.
- ▶ Mild abrasives.
- ▶ Pumping liquids with good lubricating qualities.

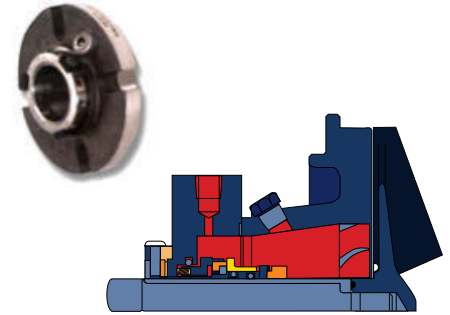

Double cartridge seal

- ▶ Same applications as conventional double seal.
- ▶ Reduced maintenance costs.
- ▶ No error when installing the seal.

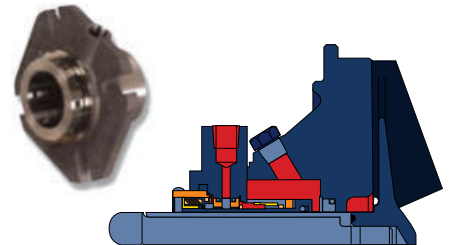

Double gas barrier seal

- ▶ Toxic or hazardous liquids.
- ▶ When an external drain is not accepted.
- ▶ When the draining liquid is not compatible or absent.

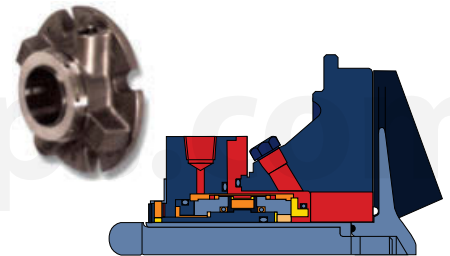

Pharmaceutical



Steel



Chemical



Pulps & paper

Increase the seal lifespan reducing maintenance costs.

The most common cause of failure in a process pump is the mechanical seal.

This failure is usually attributed to poor heat dissipation, poor lubrication on the seal faces or pumping liquids containing solids, air or vapors.

We have several seal plates designed to accommodate the best sealing system and adequate lubrication.

Ask our Barmesa Pumps distributor, he will recommend the best option with better fluid circulation in the seal, heat dissipation, etc., to increase seal and pump life.

Component interchangeability

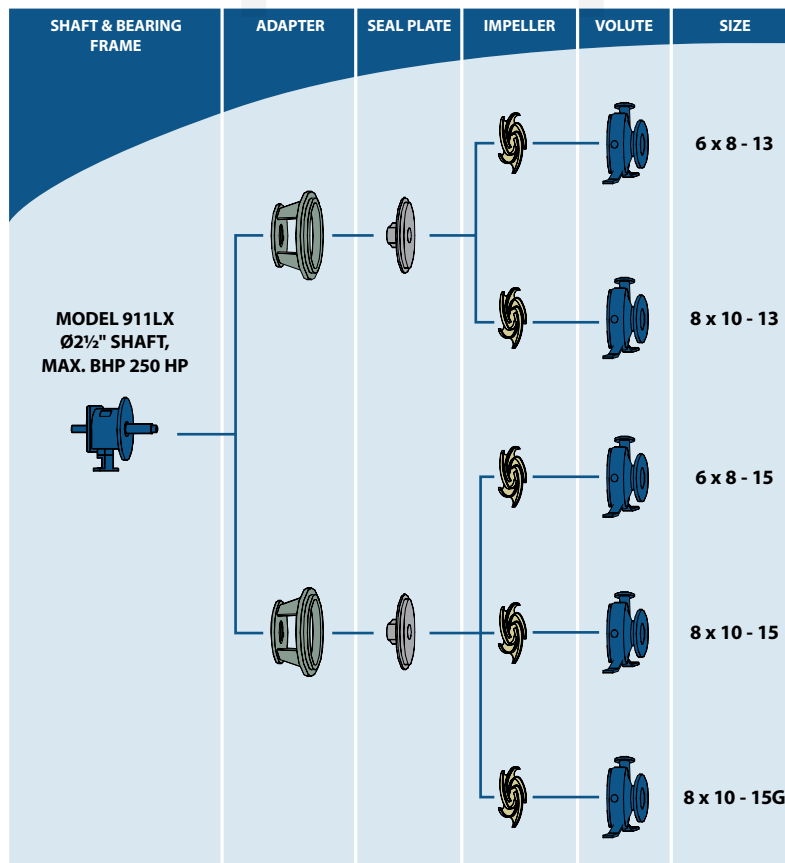
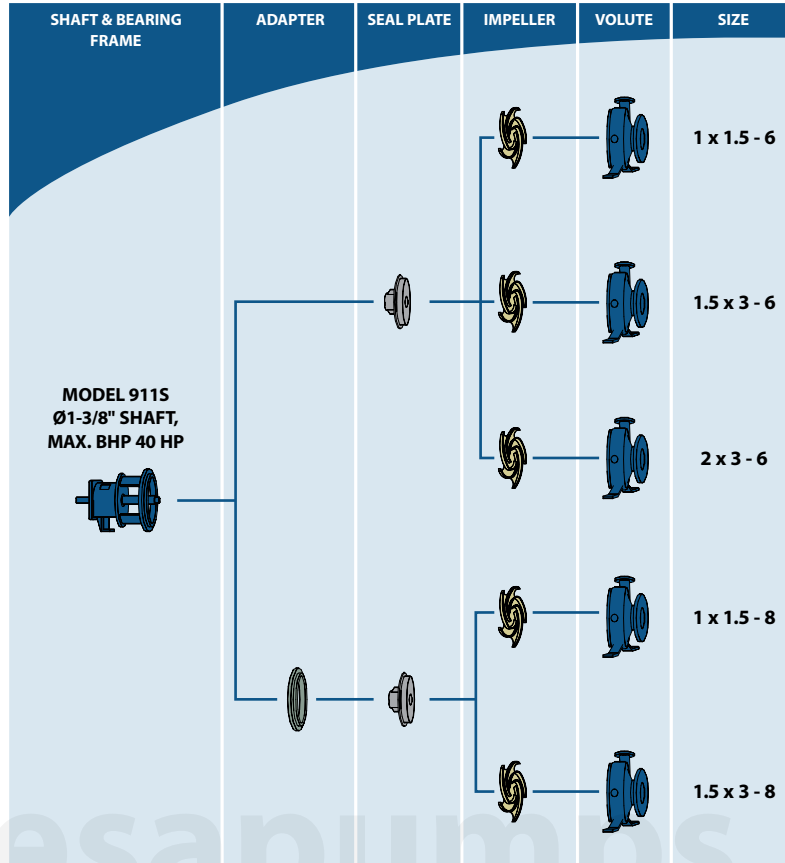

Component interchangeability

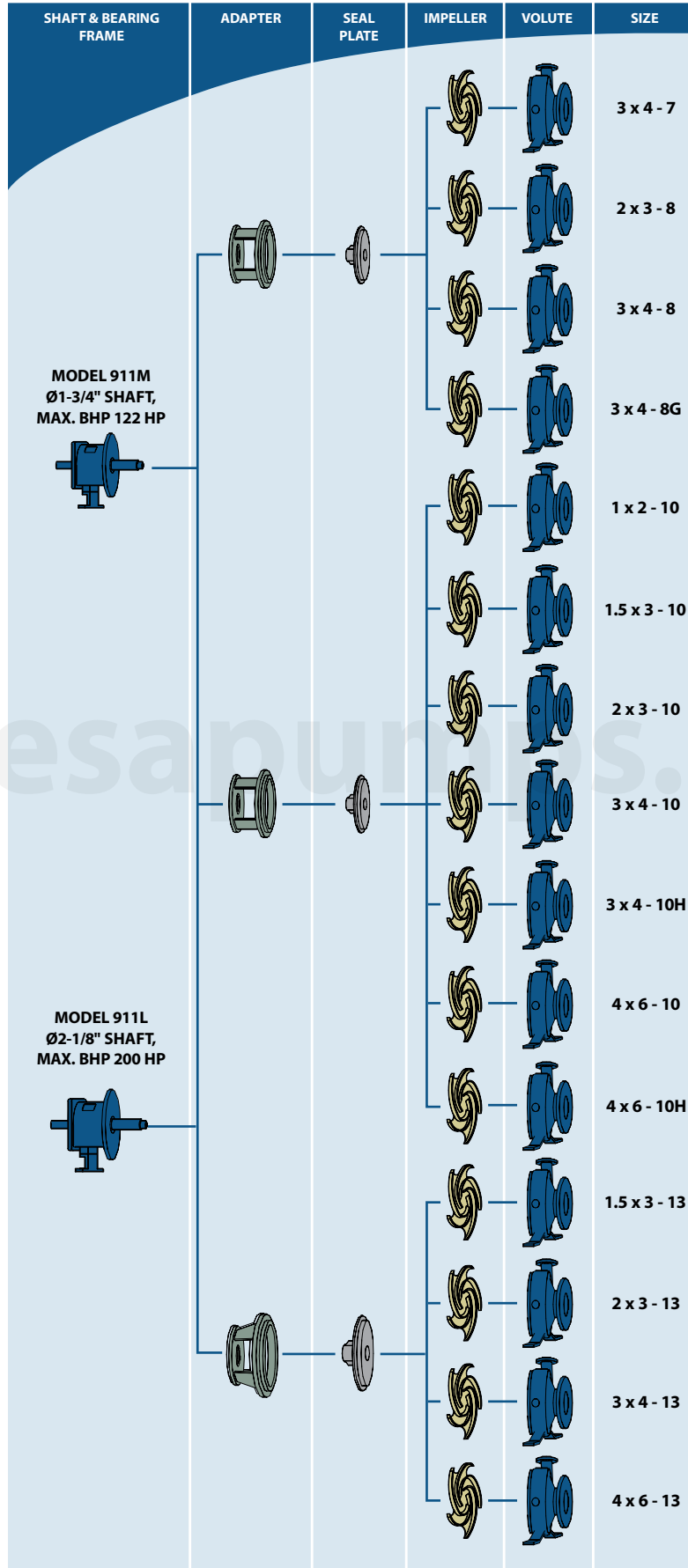

barmesapumps.com

ENGINEERING THAT OFFERS FLEXIBILITY AND DURABILITY

The 911 Series is offered in a variety of sizes, capacities and materials covering every application in the process industry.

With over 30 different sizes with multiple cooling plans and seals, the Barmesa 911 Series pumps are your best choice.

Our strict quality program ensures that all components are manufactured to the highest standard for engineered tolerances.

With controlled process in our manufacturing line we have structured a state-of-the-art pump to deliver high-level solutions meeting your most critical requirement.

CNC (computer numerically controlled) machining equipment guarantees consistency for all parts.

BEARING BOX WITH EXTRA-LARGE OIL SUMP

Large oil capacity which improves heat transfer, assuring bearing longevity, quality and performance. For higher temperature applications, a variety of cooling systems can be accommodated in the 911 Series.

EXTERNAL CLEARANCE ADJUSTMENT

To maintain flow, pressure and efficiency, the tolerance between the volute and impeller is externally calibrated, minimizing energy consumptions and repairs and maximizing its performance.

HEAVY DUTY SHAFT AND BEARINGS

Engineered in accordance to ANSI standards for chemical processing to minimize vibration and shaft deflection, less than 0.002, long-term reliable function. Solid or sleeved shaft is available in different materials. Bearings life expectancy of 10-year under tough operating conditions.

OVERSIZED ADAPTER

Its construction ensures rigidity and safety, precision machining allows perfect alignment between the liquid end and the power end.

Large openings which facilitate installation and maintenance.

LABYRINTH SEALS STANDARD

All models feature INPRO® labyrinth seal made of bronze. These seals isolate environmental contaminants from lubrication media, significantly extending bearing life.

MOUNTING FRAME FLANGE

Machined to assemble motors with C-face adapters.

OVERSIZED SIGHT GLASS

One-inch bulls-eye sight glass, located on the side of the bearing unit, facilitates monitoring oil level and condition, assuring bearing longevity and efficiency.

EXTRA-HEAVY CASTINGS

All 911 Series pumps are designed with a greater thickness than conventional wall.

- ▶ Top center line, self-venting.
- ▶ Rigid casing feet prevents pipe line misalignment.
- ▶ Back pull-out design to simplify maintenance.
- ▶ The flanges meet ANSI B 16.5 requirements, class 150 FF standard flanges and class 150 RF optional.

FULLY OPEN IMPELLER

The design of the impeller is recognized as the best in the petrochemical industry, either for handling solids, fibrous material and corrosive / abrasive fluids.

Back pump-out vanes reduce seal chamber pressure and hydraulic loads.



SEALING FLEXIBILITY

Wide range of sealing options, coupled with stuffing boxes and seal chambers to improve heat dissipation and lubrication of seal faces, maximizing pump operation.

SELF-CONTAINED VOLUTE GASKET

Provides a positive seal between the volute and the seal plate, prevents "blow out" and facilitates disassembly.

INTERCHANGEABILITY

All parts of the 911 Series are 100% interchangeable with other existing ANSI pumps. Ask your distributor for ANSI 911 parts list.

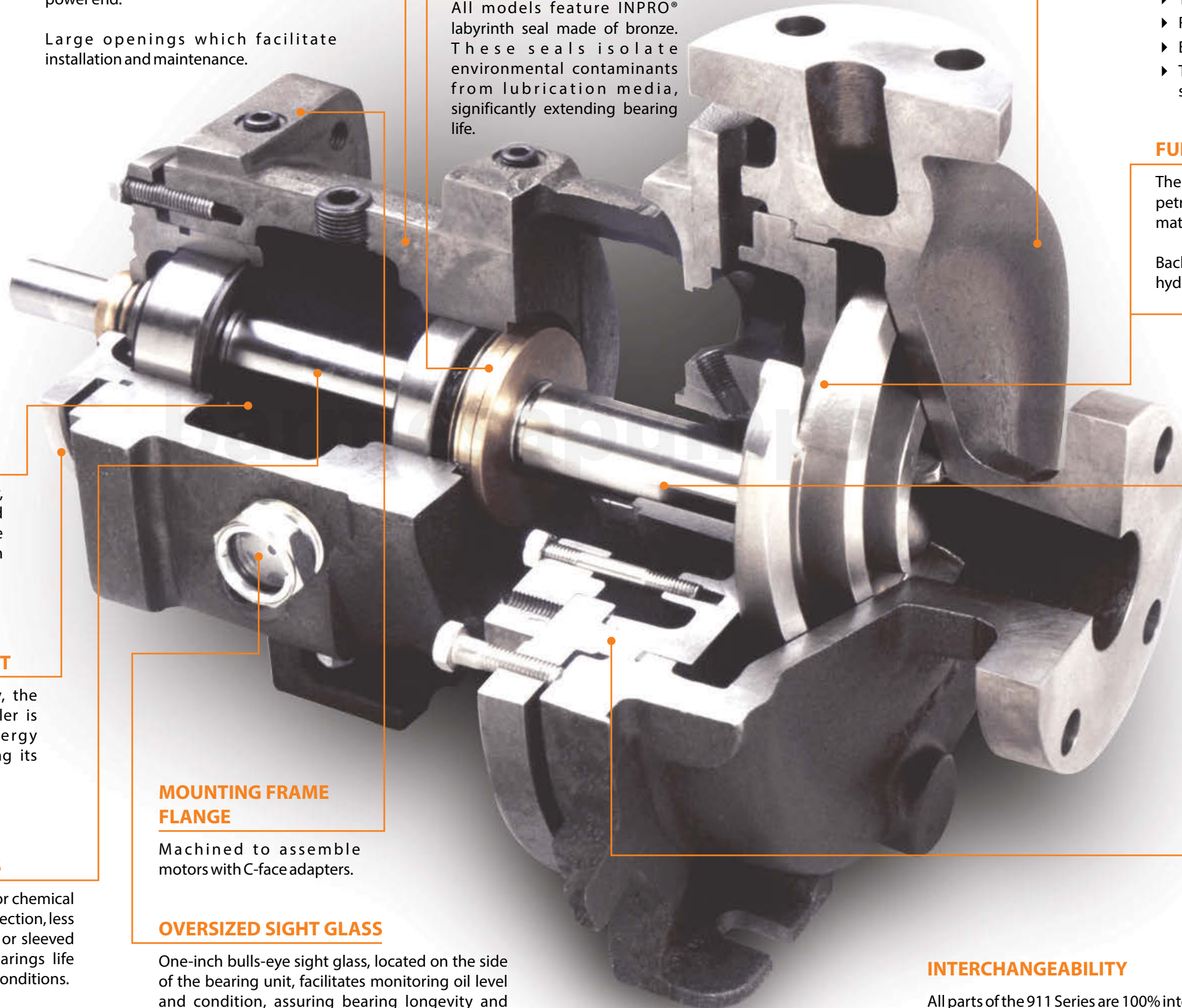

PLAN 7311

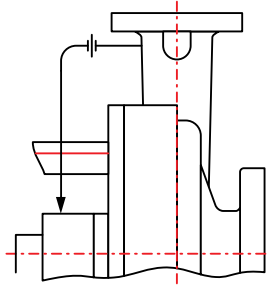

Recirculation from the volute to the mechanical seal area.

PLAN 7321

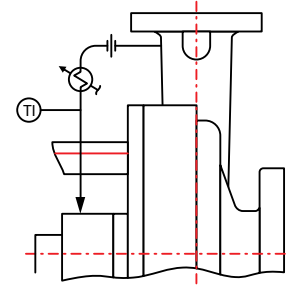

Recirculation of the volute to the heat exchanger and then to the mechanical seal area.

PLAN 7332

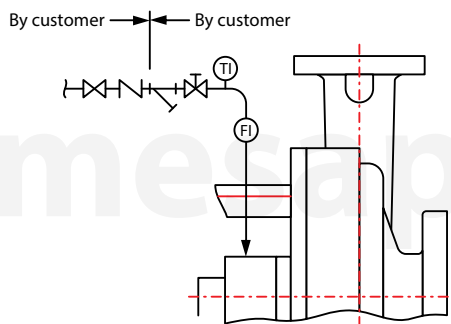

Injection in the mechanical seal from a source of clean fluid.

PLAN 7352

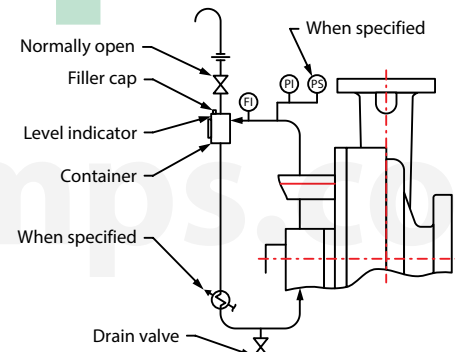

External fluid container without pressurizing; forced circulation.

PLAN 7353

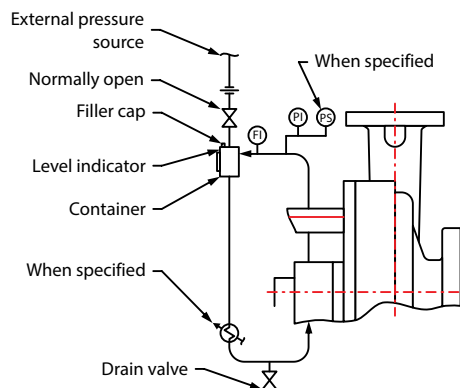

External pressurized fluid container; forced circulation.

PLAN 7354

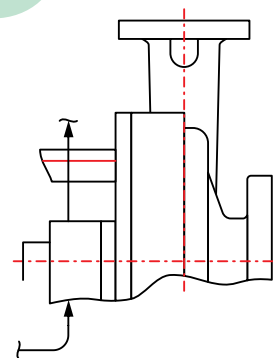

Circulation of clean fluid from an external system.

Parts list key

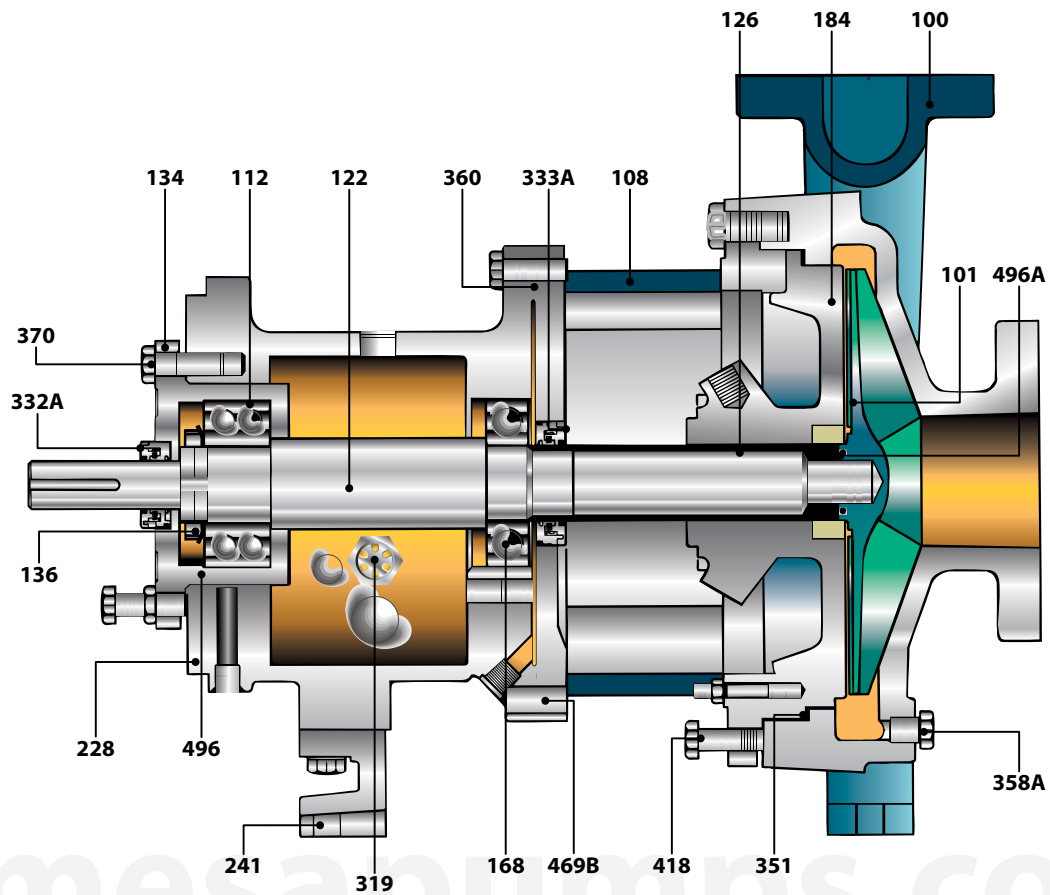

Item	Required per pump	Description	Material		
			Ductile iron	316 SS	CD4MCu
100	1	Casing	Ductile iron	316 SS	CD4MCu
101	1	Impeller	Ductile iron	316 SS	CD4MCu
108	1	Frame adapter	Ductile iron		
112	1	Outboard bearing	Steel		
122	1	Shaft - less sleeve (optional)	316 SS		
122	1	Shaft for sleeve design	AISI 4140		
126	1	Sleeve	316 SS		
134	1	Bearing housing	Ductile iron		
136	1	Thrust bearing locknut	Steel		
168	1	Inboard bearing	Steel		
184	1	Stuffing box cover	Ductile iron	316 SS	CD4MCu
228	1	Frame	Ductile iron		
241	1	Frame foot support	Ductile iron		
250	1	Flush gland mechanical seal	316 SS		CD4MCu
319	1	Sight glass	Glass / Steel		
332A	1	Outboard labyrinth seal INPRO	Bronze / Viton O-Rings		
333A	1	Inboard labyrinth seal INPRO	Bronze / Viton O-Rings		
351	1	Casing gasket	EPDM		
353	2	Gland stud	316 SS		
355	2	Gland stud nut	304 SS		
357K	2	Hex nut for 370H	304 SS		
358A	1	Drain plug (optional)	Steel	316 SS	CD4MCu
360	1	Gasket Frame-Adapter	Vellumoid		
370	3	Bolt Adapter - Casing	Steel		
418	3	Jack bolt Adapter - Casing	316 SS		
469B	2	Dowel pin Frame - Adapter	Steel		
496	2	Bearing Housing O-Ring	Buna-N		
496A	2	Impeller O-Ring	Te on		

Specifications & performance curve

MAX. WORKING PRESSURE LIMITS

MODELS 911S, M, L, LX

CLASS 150 FLANGES

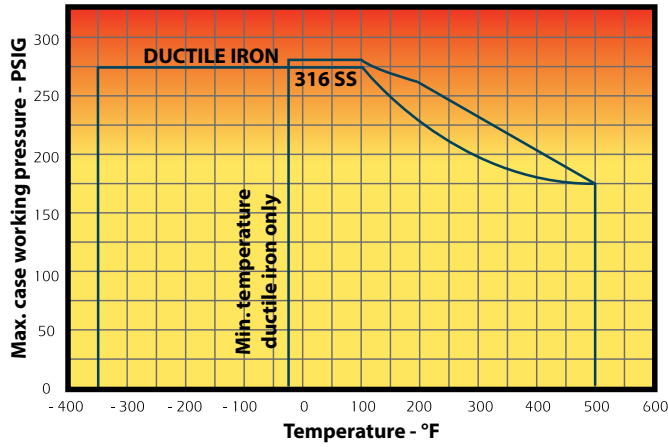

CLASS 300 FLANGES

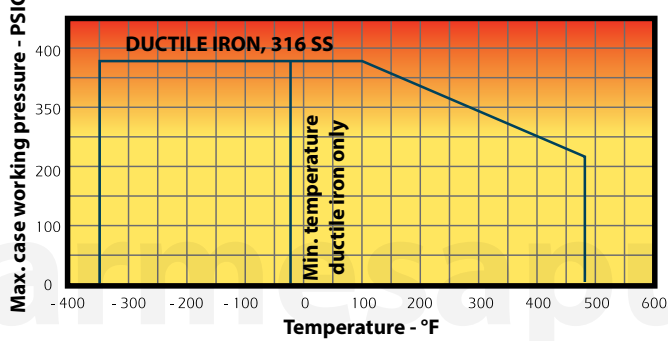

► Performance curve

3500 RPM

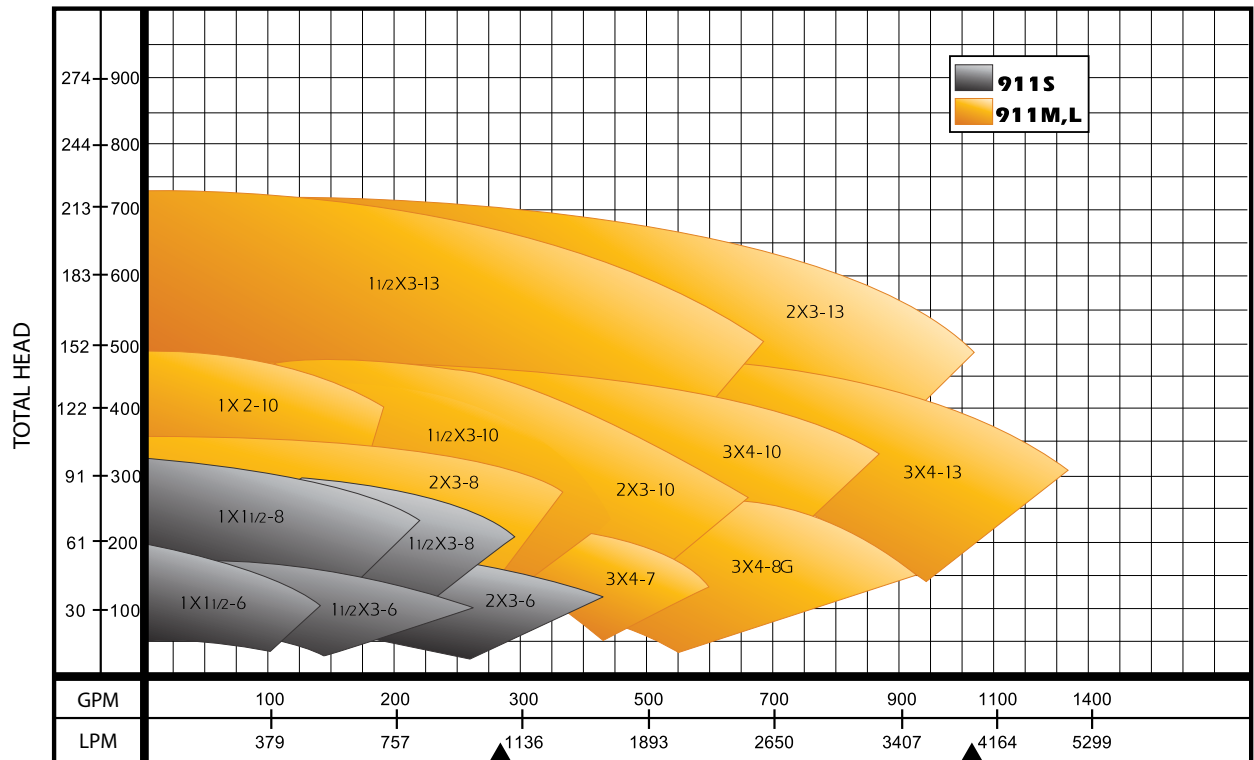

▲ = CHANGE OF SCALE

Performance curve & construction

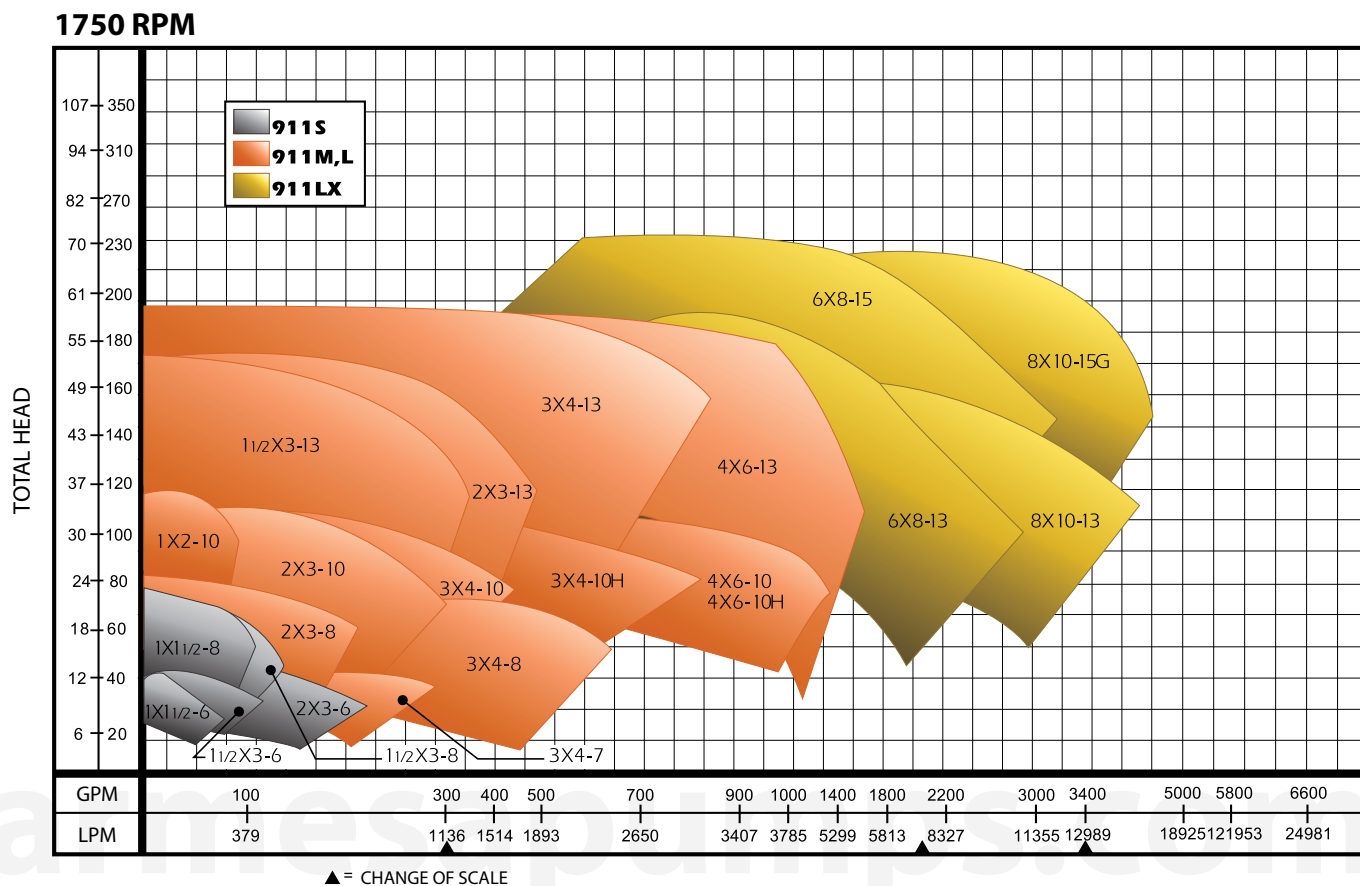

► CONSTRUCTION DETAILS

SIZE & ANSI DESIGNATION	1 x 1.5 - 6 AA	1.5 x 3 - 6 AB	2 x 3 - 6	1 x 1.5 - 8 AA	1.5 x 3 - 8 AB	3 x 4 - 7 A70	2 x 3 - 8 A60	3 x 4 - 8 A70	3 x 4 - 8G A70	1 x 2 - 10 A05	1.5 x 3 - 10 A50	2 x 3 - 10 A60	3 x 4 - 10 A70	3 x 4 - 10H A40	4 x 6 - 10 A80	4 x 6 - 10H A80	1.5 x 3 - 13 A20	2 x 3 - 13 A30	3 x 4 - 13 A40	4 x 6 - 13 A80	1 x 2 - 10 A05	1.5 x 3 - 10 A50	2 x 3 - 10 A60	3 x 4 - 10 A70	3 x 4 - 10H A40	4 x 6 - 10 A80	4 x 6 - 10H A80	1.5 x 3 - 13 A20	2 x 3 - 13 A30	3 x 4 - 13 A40	4 x 6 - 13 A80	6 x 8 - 13 A90	8 x 10 - 13 A100	6 x 8 - 15 A110	8 x 10 - 15 A120	8 x 10 - 15G A120
	MODEL	911 S				911 M (max. BHP 122 HP)										911 L (max. BHP 200 HP)						911 LX														
CASING	NOMINAL CASE THICKNESS	3/8"				1/2"										9/16"						1/2"														
	CORROSIVE ALLOWANCE @ MAX.	1/8"																																		
	WORKING PRESSURE	LIMITS SET BY ANSI B16.5																																		
	MAX. WORKING PSIG	SEE PRESSURE / TEMPERATURE CHARTS																																		
	HYDRO TEST PSIG @ 100 °F	150% OF WORKING PRESSURE																																		
MAX. LIQUID TEMPERATURE	350 °F WITHOUT COOLING																																			
SHAFT	DIAMETER AT COUPLING	7/8"				1 1/8"										1 7/8"						2 3/8"														
	SLEEVE DIAMETER UNDER SEAL	1 3/8"				1 3/4"										2 1/8"						2 1/2"														
	IMPELLER THREAD	3/4"				1"										1 1/4"						1 1/2"														
	DIAMETER WITHOUT SLEEVE	1 1/8"				1 1/2"										1 7/8"						2"														
	OVERHANG	6"				7 7/8"										8"						9"														
BEARINGS	THRUST BEARING	SKF 5306A/C3				SKF 5309A/C3										SKF 7310 BECBM (DOUBLE)						SKF 5313A/C3														
	RADIAL BEARING	SKF 6207				SKF 6309										SKF 6311						SKF 6313														
	BEARING SPAN	6"				5 1/16"										4 1/4"						5"														
STUFFING BOX STD.	MECHANICAL SEAL SIZE	1 3/8"				1 3/4"										2 1/8"						2 1/2"														
	INSIDE DIAMETER	2"				2 1/2"										2 7/8"						3 3/8"														
	DEPTH	2 1/8"				2 1/2"										2 5/8"						3"														
	DISTANCE END OF BOX TO NEAREST OBSTRUCTION	2 3/8"				2 1/2"										2 13/16"						2 7/8"														
LANTERN RING WIDTH	7/16"														5/8"						5/8"															

General dimensions

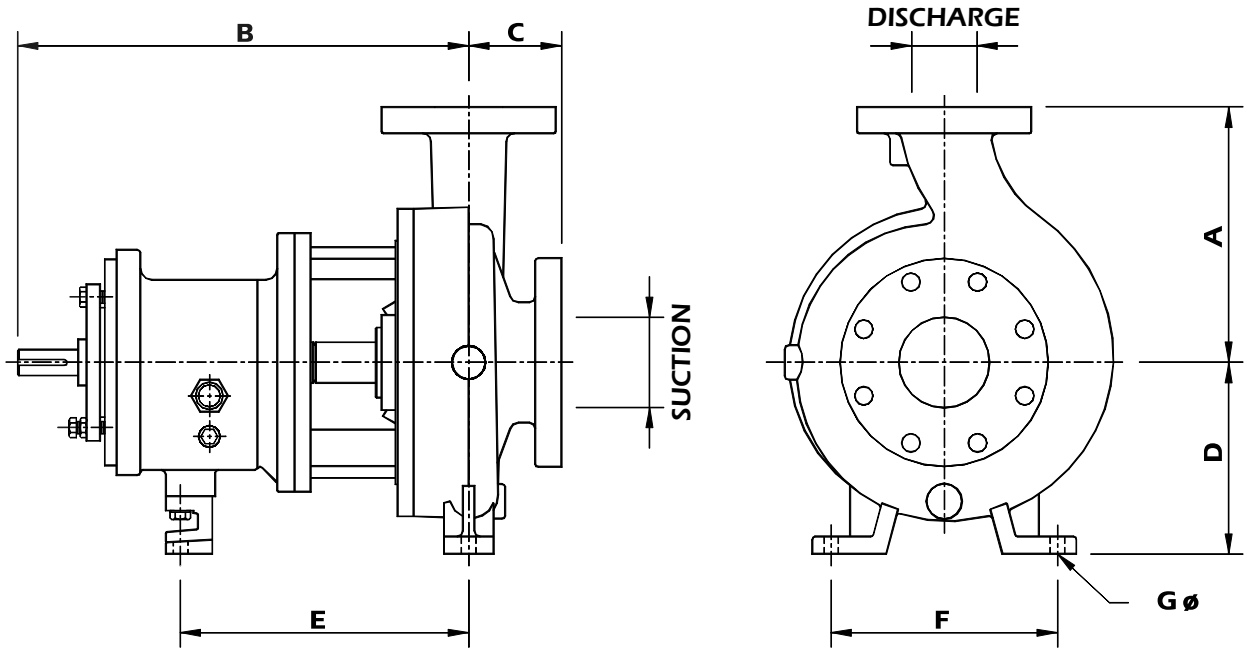

MODEL	PUMP SIZE	ANSI DESIGNATION	DISCHARGE DIAM.	SUCTION DIAM.	A	B	C	D	E	F	ØG HOLES	APROX. WEIGHT (kg)
911S	1 x 1.5 - 6	AA	1	1.5	6.5"	13.5"	4"	5.25"	7.25"	6"	0.625"	38
	1.5 x 3 - 6	AB	1.5	3								42
	2 x 3 - 6	-	2	3								43
	1 x 1.5 - 8	AA	1	1.5							0.563"	45
	1.5 x 3 - 8	AB	1.2	3								49
911M & 911L	3 x 4 - 7	A70	3	4	11"	19.5"	4"	8.25"	12.5"	9.75"	0.625"	100
	2 x 3 - 8	A60	2	3	9.5"							91
	3 x 4 - 8	A70	3	4	11"							100
	3 x 4 - 8G	A70	3	4	11"							100
	1 x 2 - 10	A05	1	2	8.5"							91
	1.5 x 3 - 10	A50	1.5	3	8.5"							100
	2 x 3 - 10	A60	2	3	9.5"			104				
	3 x 4 - 10	A70	3	4	11"			120				
	3 x 4 - 10H	A40	3	4	12.5"			138				
	4 x 6 - 10	A80	4	6	13.5"			138				
	4 x 6 - 10H	A80	4	6	13.5"			138				
	1.5 x 3 - 13	A20	1.5	3	10.5"			10"				111
	2 x 3 - 13	A30	2	3	11.5"						125	
	3 x 4 - 13	A40	3	4	12.5"						150	
4 x 6 - 13	A80	4	6	13.5"	184							
911LX	6 x 8 - 13	A90	6	8	16"	27.9"	6"	14.5"	18.75"	16"	0.875"	254
	8 x 10 - 13	A100	8	10	18"							304
	6 x 8 - 15	A110	6	8	18"							277
	8 x 10 - 15	A120	8	10	19"							336
	8 x 10 - 15G	A120	8	10	19"							710

General dimensions (with baseplate)

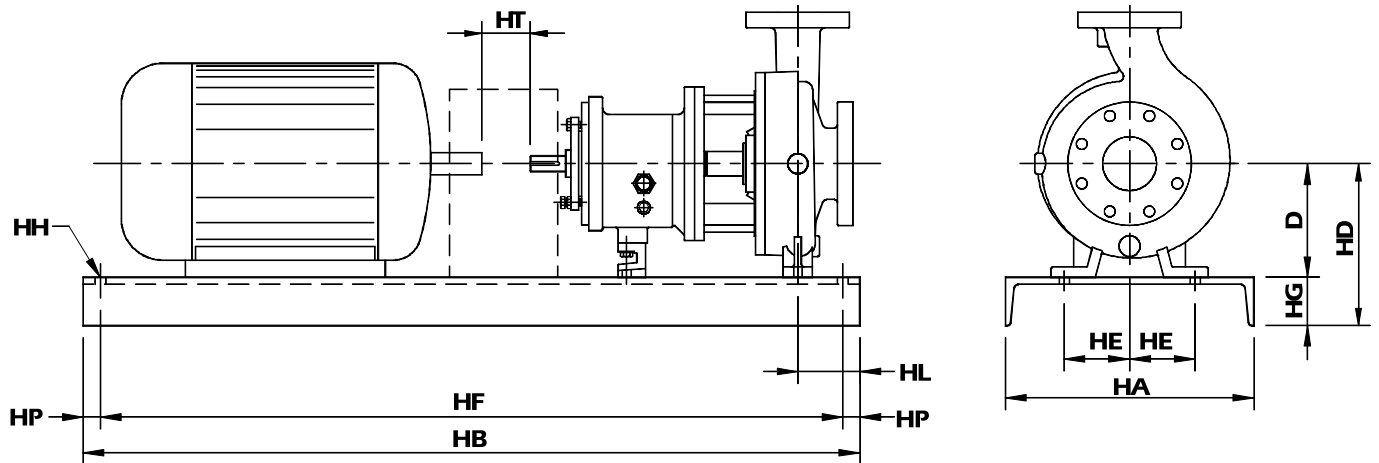

NEMA FRAME	BASEPLATE NUMBER	HA MAX.	HB MAX.	HT MIN.	HD MAX.				HE	HF	HG MAX.	HH	HL	HP
					D=5.25"	D=8.25"	D=10"	D=14.5"						
184T	139	15"	39"	3.5"	9"	-	-	-	4.5"	36.5"	3.75"	0.75"	4.5"	1.25"
256T	148	18"	48"	3.5"	10.5"	-	-	-	6"	45.5"	4.13"	0.75"	4.5"	1.25"
326TS	153	21"	53"	3.5"	12.88"	-	-	-	7.5"	50.5"	4.75"	0.75"	4.5"	1.25"
184T	245	15"	45"	3.5"	-	12"	13.75"	-	4.5"	42.5"	3.75"	0.75"	4.5"	1.25"
215T	252	18"	52"	3.5"	-	12.38"	14.13"	-	6"	49.5"	4.13"	0.75"	4.5"	1.25"
286T	258	21"	58"	3.5"	-	13"	14.75"	-	7.5"	55.5"	4.75"	1"	4.5"	1.25"
365T	264	21"	64"	3.5"	-	13.88"	14.75"	-	7.5"	61.5"	4.75"	1"	4.5"	1.25"
405TS	268	26"	68"	3.5"	-	14.88"	14.88"	-	9.5"	65.5"	4.75"	1"	4.5"	1.25"
449TS	280	26"	80"	3.5"	-	15.88"	15.88"	-	9.5"	77.5"	4.75"	1"	4.5"	1.25"
286T	368	26"	68"	5"	-	-	-	19.25"	9.5"	65.5"	4.75"	1"	6.5"	1.25"
405TS	380	26"	80"	5"	-	-	-	19.25"	9.5"	77.5"	4.75"	1"	6.5"	1.25"
449TS	398	26"	98"	5"	-	-	-	19.25"	9.5"	95.5"	4.75"	1"	6.5"	1.25"



FOR MORE INFORMATION CONTACT:

**APPLIED
PROCESS**

EQUIPMENT, INC.



PUMPS AND TANKS

9332 N. 95th Way
Scottsdale, AZ 85258
480-998-4097
sales@apewater.com

www.barmesapumps.com

© Barmesa Pumps LLC. All rights reserved.