

## Introducing the HIC+ Series Industrial Stainless Steel Pumps



- Constructed of 316L Stainless Steel
- Glass Beaded Finish
- Standard NPT or Flanged connections
- Type 21 mechanical seal, with multiple material options
- Includes standard stainless adapter
- 10 day lead time
- Ideal for non-sanitary applications

For more information contact:

Haight Pumps 133 Enterprise Street • Evansville, WI 53536 Phone: 800-871-9250 • Fax: 608-882-3777  
Website: [haightpump.com](http://haightpump.com)

# Haight HIC+ Series

## Industrial Stainless Steel Pumps

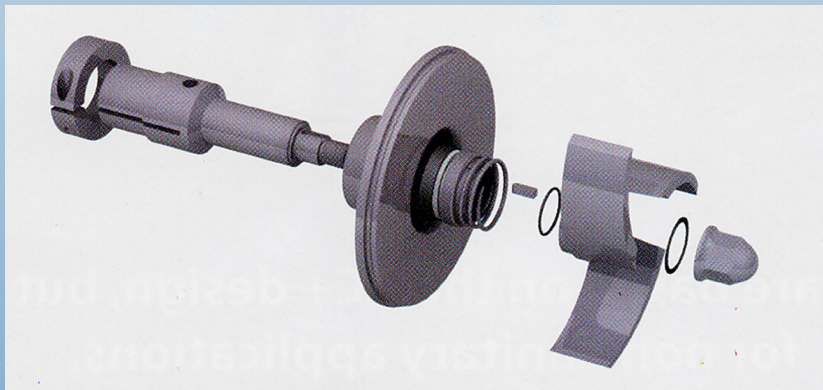
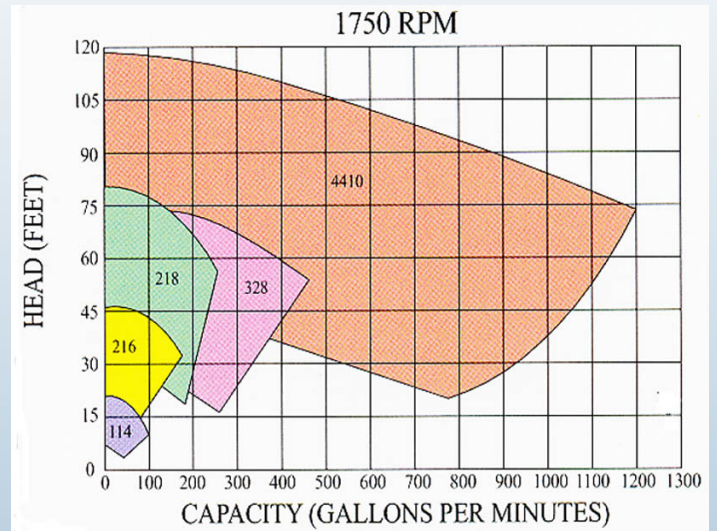
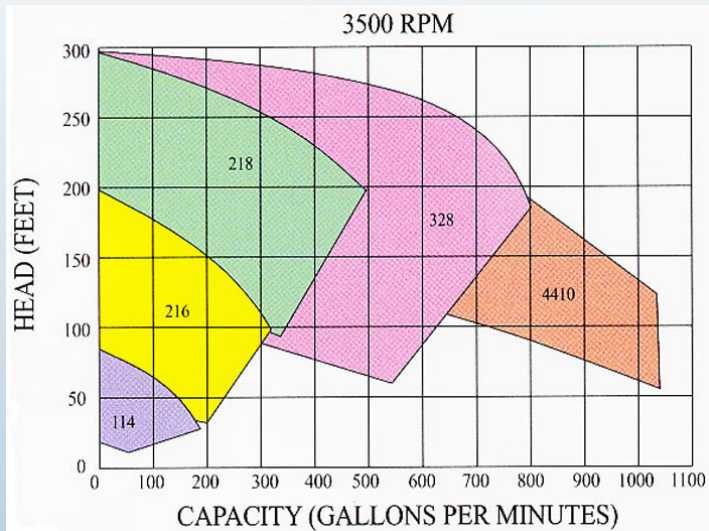

Shaft design with type 21 seal

For more information contact:

Haight Pumps 133 Enterprise Street • Evansville, WI 53536

Phone: 800-871-9250 • Fax: 608-882-3777

Website: [haightpump.com](http://haightpump.com)